

F Series

CYLINDRICAL LEVERSET (CLUTCH)

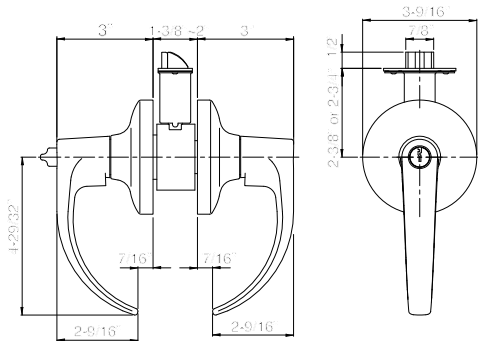

500FC-CT
Charlotte (CT) Lever

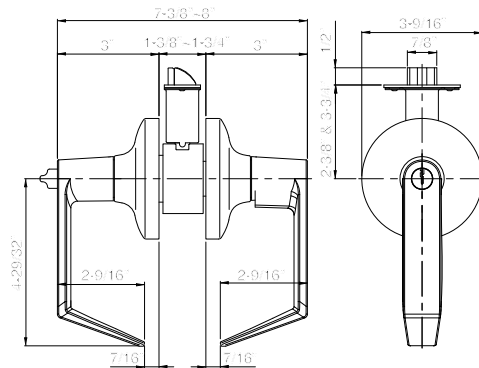

500FK-CT
Charlotte (CT) Lever



500FC-SD
San Diego (SD) Lever

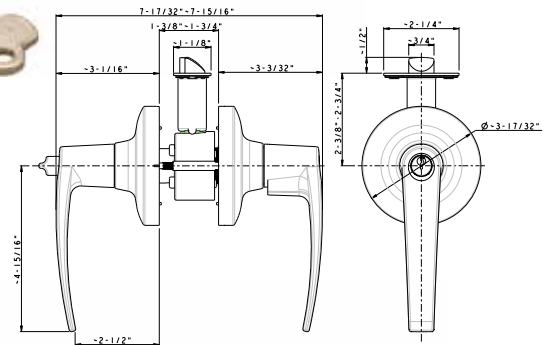

Features

- SC4 6-pin Standard
- Independent Torsion Springs
- Fast and Easy Installation
- Clutch Function Standard
- Removable Through Bolt, 2-3/4" CTC
- Panic Proof (inside always free)
- Concealed Mounting Screws

FC Series: Lock with standard cylinder or no cylinder

FK Series: Lock with interchangeable core design

FSE Series: Electrified - Failure Secure



500FC-MD
Madison (MD) Lever

ANSI GRADE 1 CLUTCH

LIFETIME Warranty

ANSI GRADE 1
ANSI/BHMA A156.2-2003
Series 4000, Grade 1
Exceeds 800,000 cycles



3 hours Fire rating
UL10C/UBC 7-2(1997)
Positive Pressure Rated



ADA compliant
ANSI A117.1
Barrier Free
Accessibility

**CALIFORNIA STATE
REFERENCE CODE**
Formerly Title 19,
California State Fire Marshal (CSFM)
levers return to within 1/2" of door face

Specifications

Door Fitting	1-3/8" ~ 2" door thick. Factory preset at 1-3/4". Thru-Bolt CTC: 2-3/4".
Exposed Trim	Wrought brass. Pressure cast zinc lever.
Lock Chassis	Heavy gauge dichromated steel. Zinc dichromated for corrosion resistance.
Cylinder	Solid brass SC4 6-pins standard. KW1 5-pins optional.
Latch	1/2" throw, 7/8" dia. stainless steel latch bolt. 1-1/8" x 2-1/4" faceplate. Floating latch design fits both flat or beveled doors 1/8" in 2".
Strike	ASA strike standard (9109). T-Strike optional (9106).
Handing	Universal, non-handing.
Screws	Combination screws for both metal and wood doors.
Keys	2 brass keys per set. Key as requested (KA, KD, MCK, MK, GMK).
IC Core	Model: 500FK-CT and 500FK-SD. SFIC compatible with BEST profile 6-pins and 7-pins.
Electrified	Model: 504FSE. Failure Secure Type, Input DC-12V/24V.

3/4" Throw Anti-Friction Latch



F9070T3
Dead latch for 2-3/4" backset
1-1/8" x 2-1/4" faceplate
For use fire rated pair of doors

Removable Through Bolt

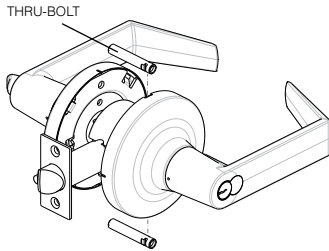

* Note: Install w/o thru-bolts void ANSI Grade 1, and warranty.

Adjustable Door Fitting

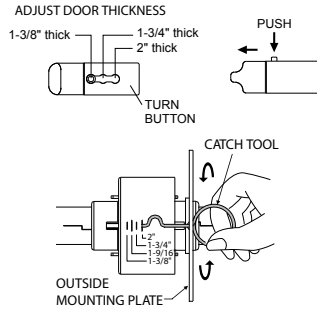

Floating Latch Design

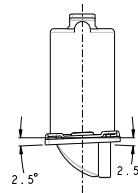

Adjustable for flat or beveled doors 1/8" in 2"

Door Preparation

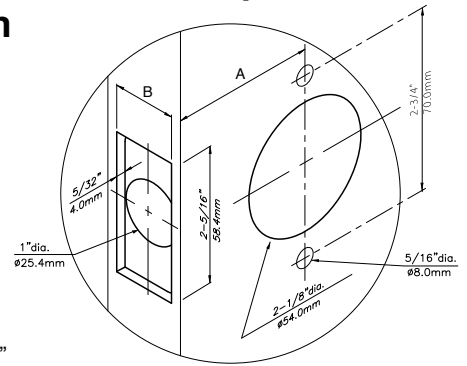

Backset	2-3/4"	2-3/8"
A	2-3/4"	2-3/8"
B	1-3/16"	1-3/16"

Latch & Parts



F9060T
Dead Latch for 2-3/8" backset
F9070T
Dead Latch for 2-3/4" backset



1214
5" backset
extension tube
(use with 2-3/4" backset latch)

521FC/FK Corridor Function Only
F9069T
Kick-off Dead Latch for 2-3/8" backset
F9079T
Kick-off Dead Latch for 2-3/4" backset



F9063T (kick-off)
Spring Latch for 2-3/8" backset
F9073T (kick-off)
Spring Latch for 2-3/4" backset

Strike



9109 ASA Strike
1-1/4" x 4-7/8", 5/8" lip



9106 T-Strike
1-1/8" x 2-3/4"

Thru-Bolt Jig (Metal)

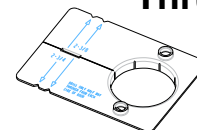

9234
2-3/8" or 2-3/4" backset
Vertical CTC 2-3/4"