

# E Series CYLINDRICAL LEVERSET (CLUTCH)

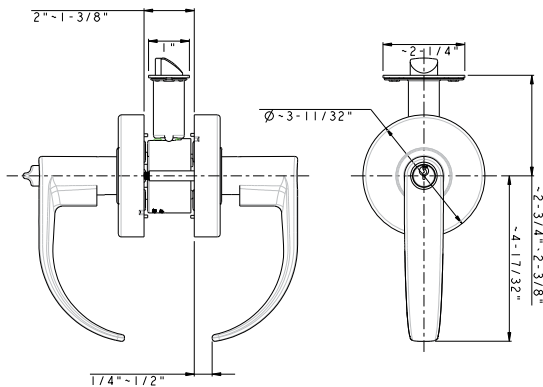

500EV-CT  
Charlotte (CT) Lever

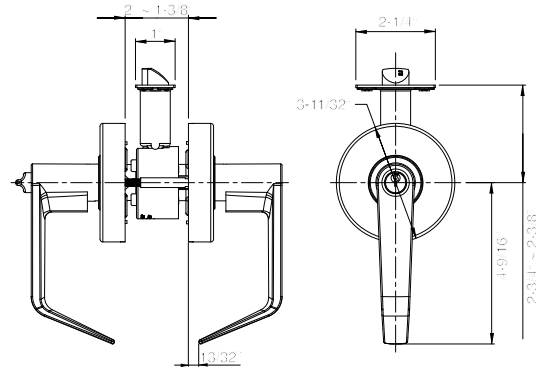

500EC-CT  
Charlotte (CT) Lever



500EV-SD  
San Diego (SD) Lever

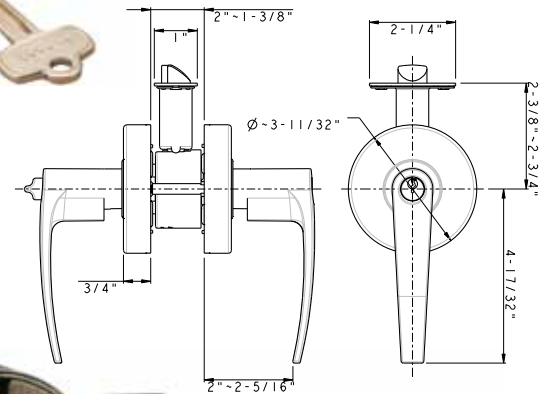

500EV-MD  
Madison (MD) Lever

## Features

- SC4 6-pin Standard
- Independent Torsion Spring
- Fast and Easy Installation
- Clutch Function Standard
- Removable Through Bolt, 2-3/4" CTC
- Panic Proof (inside always free)
- Concealed Mounting Screws

**EV Series:** Lock with standard cylinder or no cylinder

**EC Series:** Lock with interchangeable core design

# ANSI GRADE 2 CLUTCH

## LIFETIME Warranty

**ANSI GRADE 2**  
ANSI/BHMA A156.2-2003  
Series 4000, Grade 2  
Exceeds 400,000 cycles



3 hours Fire rating  
UL10C/UBC 7-2(1997)  
Positive Pressure Rated



ADA compliant  
ANSI A117.1  
Barrier Free  
Accessibility

**CALIFORNIA STATE  
REFERENCE CODE**  
Formerly Title 19,  
California State Fire Marshal (CSFM)  
levers return to within 1/2" of door face

## Specifications

Door Fitting	1-3/8" ~ 2" door standard. Factory preset at 1-3/4". Thru-Bolt CTC: 2-3/4".
Exposed Trim	Wrought brass. Pressure cast zinc lever.
Lock Chassis	Heavy gauge dichromated steel. Featuring a solid zinc rosette, both interior and exterior for extra security.
Cylinder	Solid brass SC4 6-pins standard. KW1 5-pins optional.
Latch	1/2" throw stainless steel latch bolt. Square corner faceplate standard, round corner available. 2-3/4" backset: 1-1/8" x 2-1/4" faceplate. Optional for 1" width. 2-3/8" backset: 1" x 2-1/4" faceplate. Foating latch design fits both flat or beveled doors 1/8" in 2" Backset: 2-3/4" stanard, optional for 2-3/8", 3-3/4" & 5".
Strike	ASA Strike standard (9109).
Handing	Universal, non-handing.
Screws	Combination screws for both metal and wood doors.
Keys	2 brass keys per set. Key as requested (KA, KD, MCK, MK, GMK).
IC Core	EC series, e.g. 500EC for Entrance. SFIC compatible with BEST profile 6-pins and 7-pins.

## Removable Through Bolt

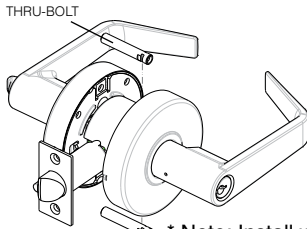

\* Note: Install w/o thru-bolts void  
ANSI Grade 2, and warranty.

## Adjustable Door Fitting

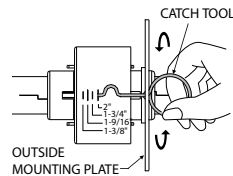

## Floating Latch Design

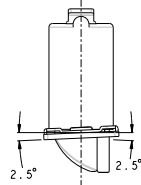

Adjustable for flat or  
beveled doors 1/8" in 2"

## Door Preparation

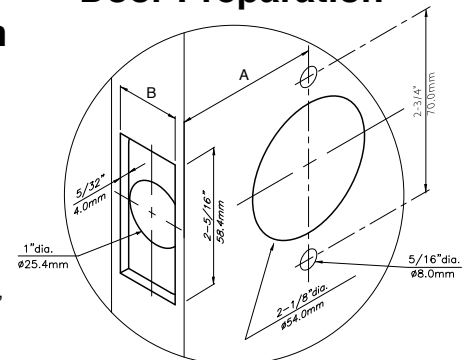

## Latch & Parts



**E9060T**  
Dead Latch for 2-3/8" backset  
**E9070T**  
Dead Latch for 2-3/4" backset



**521EV/EC Corridor Function Only**  
**E9069T**  
Kick-off Dead Latch for 2-3/8" backset  
**E9079T**  
Kick-off Dead Latch for 2-3/4" backset

**E9063T (kick-off)**  
Spring Latch for 2-3/8" backset  
**E9073T (kick-off)**  
Spring Latch for 2-3/4" backset

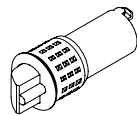

**E9060C**  
Drive-in Dead. Latch for 2-3/8" backset  
**E9070C**  
Drive-in Dead. Latch for 2-3/4" backset

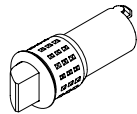

**E9063C (kick-off)**  
Drive-in Spring. Latch for 2-3/8" backset  
**E9073C (kick-off)**  
Drive-in Spring. Latch for 2-3/4" backset

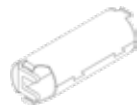

**2214**  
5" backset  
extension tube  
(use with 2-3/4" backset latch)  
**2138**  
3-3/4" backset  
extension tube  
(use with 2-3/8" backset latch)

Backset	2-3/4"	2-3/8"
A	2-3/4"	2-3/8"
B	1-3/16"	1-1/16"

## Strike



**9109 ASA Strike**  
1-1/4" x 4-7/8", 5/8" lip

**9106 T-Strike**  
1-1/8" x 2-3/4"



**1180**  
Faceplate Adapter  
Use on 1" width for  
1-1/8" width requirement

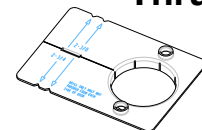

## Thru-Bolt Jig (Metal)

**9234**  
2-3/8" or 2-3/4" backset  
Vertical CTC 2-3/4"