



Philadelphia Hardware Group, Inc.

6590 Top Gun St.
 San Diego, CA 92121
 www.philhardware.com
 Tel: 858-642-0450
 Fax: 858-642-0454
 V052623

Advantage Exit Device EL5 Series Lever Trim

Features

- Designed to Use with Grade 1 Exit Device
- Clutch Function Standard
- Standard For 1-3/4" Door Thickness
- Optional For 2" Door Thickness
- Hardened Steel Heavy Duty Tailpiece



Specifications

Certification	California State Reference Code: (Formerly Title 19, California State Fire Marshall Standard) For Levers with Returns to Within 1/2" of Door Face.
Exposed Trim	Wrought Stainless Steel with Steel Construction, Pressure Cast Zinc Lever
Keys	2 Keys Per Set. Keying As Requested (KA, KD, MCK, MK, GMK)
Cylinder	SCC Standard Optional with SFIC, KW1
Lever Style	CT (Charlotte), SD (San Diego), MD (Madison)
Finishes (BHMA)	US26D (626), US10B (613), US19 (622)

Dimensions

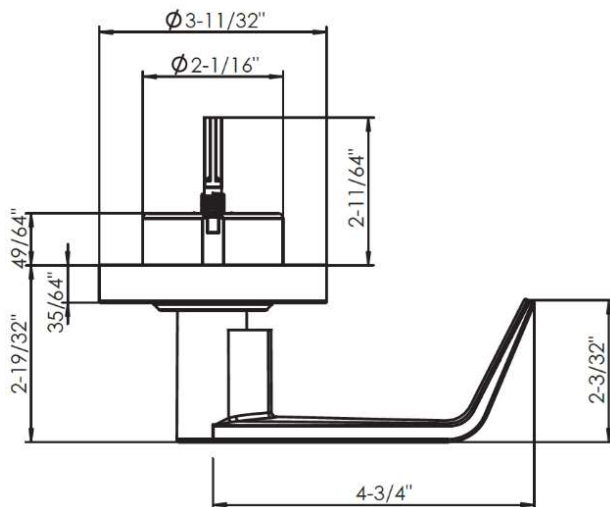

Functions

- EL500 – Entry
 - EL504 – Storeroom
 - EL501 – Passage
 - EL500ICB – SFIC Entry*
 - EL504ICB – SFIC Storeroom*
- *SFIC (Less Core)

SAN DIEGO • **CHICAGO** • **ATLANTA** • **DALLAS**