



Philadelphia Hardware Group, Inc.

6590 Top Gun St.
San Diego, CA 92121
www.philhardware.com
Tel: 858-642-0450
Fax: 858-642-0454
V091423

Advantage Door Closer 2000 Series

**COMMERCIAL
GRADE 2**

GRADE 2
Factory tested to meet
ANSI Grade 2 durability

 **UL**
LISTED
UL10C Positive Pressure
Rated. Conforms to UBC
7-2 (1997). (Uniform
Building Code Standard)



Features

- Power Size #2
- Tri-Packed For All Types of Installation



Specifications

Material	Aluminum Alloy Body, Forged Steel Arm, Heat Treated Forged Steel Piston, Double Heat Treated Steel Pinion
Valves	Staked Valve For Adjustments Dual Valve Control – Closing Speed & Latching Speed
Arms & Brackets	Standard With Regular Arm and Parallel Bracket
Screws	Standard With Self Tapping Wood Screws & Machines Screws
Model	2000 – Power Size #2
Finish	ALUM (689), DURO (695), GOLD (696), BLACK (693)

Technical Dimensions

- A.) Length of Closer Body – 7-5/16"
- B.) Horizontal Mounting Holes – 6-5/8"
- C.) Vertical Mounting Holes – 3/4"
- D.) Height of Closer Body – 1-3/4"
- E.) Projection From Door – 2-5/8"

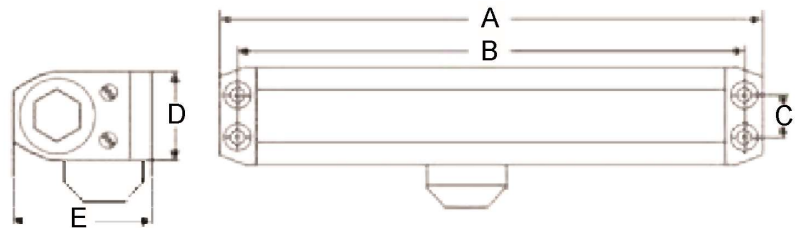

SAN DIEGO

CHICAGO

ATLANTA

DALLAS





Philadelphia Hardware Group, Inc.

6590 Top Gun St.
 San Diego, CA 92121
 www.philhardware.com
 Tel: 858-642-0450
 Fax: 858-642-0454
 V091423

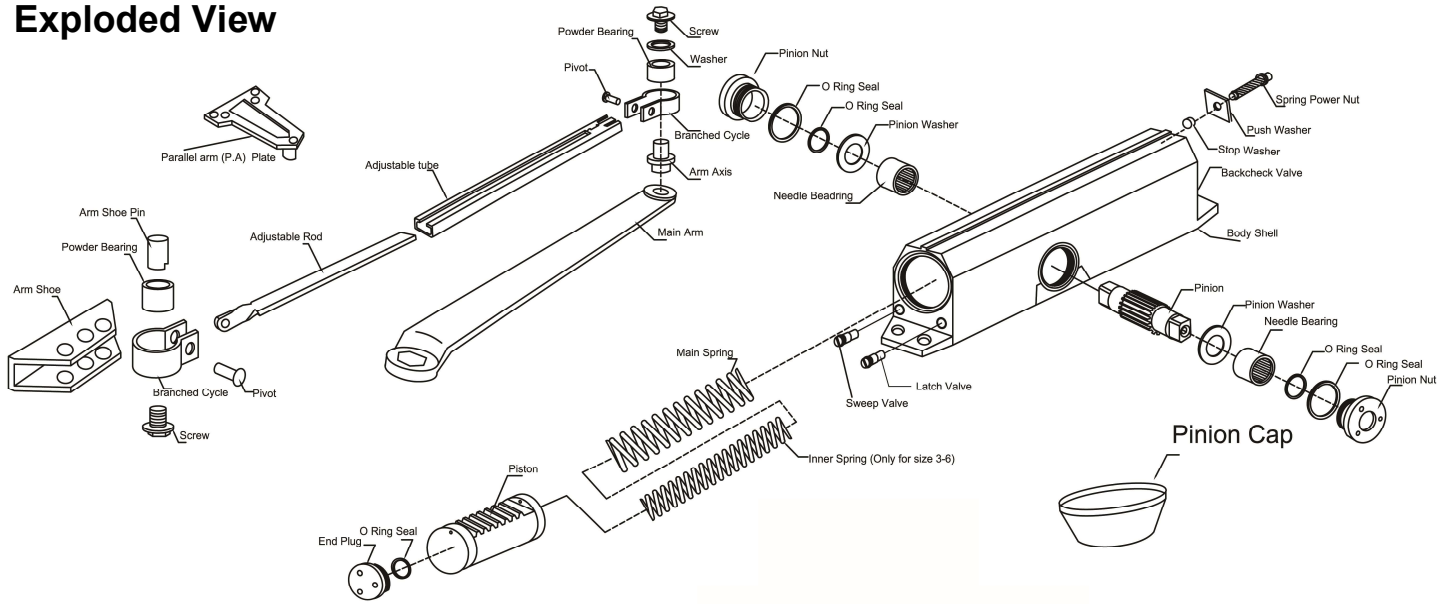
Exploded View



Accessories

<p>PAB02 Parallel Bracket</p> 	<p>1344 Sex Bolts</p> 	<p>20DPPA Drop Plate – Parallel</p> 		
---	---	---	--	--

SAN DIEGO

CHICAGO

ATLANTA

DALLAS